



**PQ Star Test Program
SEMI F47 Compliance Certificate
Certification Date: 01/05/05**

PQ Star Reference Number
SEMIF47.097

Manufacturer: PULS

Product: Dimension 24Vdc Power
Supply

Model Number: QS5.241

Serial Number (Unit Tested):
2433681

**See Attachments for SEMI F47
Description and Detailed Test Results.**

Test Configuration: The Power Supply
was tested using SEMI F42 compliant
voltage sag generator equipment. See
Attachment B for details.

Test Date: 01/04/05

Test Location:
EPRI Solutions, Inc (ESI)
942 Corridor Park Blvd
Knoxville, TN 37932

Electrical Environment:
120/208Vac Single Phase, 50/60 Hz
(See Attachment A for details.)

This letter and subsequent documentation certifies that the PULS Dimension QS5.241 power supply detailed in this document, in its original configuration has been voltage sag tested per **SEMI F42** test protocol and was found to comply with the **SEMI F47** voltage sag immunity standard at 100% load, 50/60Hz at 120/208Vac. This certification remains valid to the model tested only and as long as no component substitutions are made.

Certified by,

Dennis Turner
PQ Star Certification Specialist
EPRI Solutions, Incorporated



PULS QS5.241 Power Supply



Attachment A – SEMI F47 Test Results

Testing was performed in ESI’s Power Quality Laboratory in Knoxville, TN. The test protocol followed was SEMI F42 Test Method for Semiconductor Processing Equipment Voltage Sag Immunity. To ensure maximum accuracy of the test, a variable voltage source was used to set the voltage to exactly 120/208Vac. This was verified at the power supply with a qualified meter. During the voltage sag test, the power supply was connected to a electronic variable load bank and loaded to 100%. Table A-1 shows the power supplies rated full load conditions, and the actual load it was tested at.

Table A-2 lists all points tested per SEMI F42 test method, and Figure A-1 shows the power supplies specific SEMI F47 ride-through curve at 120Vac, and Figure A-2 shows the power supplies specific SEMI F47 ride-through curve at 208Vac. The SEMI specific points are highlighted for both 50 and 60 Hz. The power supply was tested at points below the curve to fully characterize the components. During the testing of SEMI F47 test points (1s at 80%, 0.5s at 70%, 0.2s at 50%, and 0.05s at 50%) the output voltage of the power supply did not deviate. Deviation is noted in the test tables and at what points the output voltage deviated. It’s important to note that the power supply passed at 50 and 60 Hz, loaded to 100% load.

Table A-1. Power Supply Ratings

Evaluated at 120/208Vac							
Manufacture	Power Supply	Vdc	I	R	W	Actual load	Result
PULS	QS5.241	24	5	4.8	120	100%	PASSED

Table A-2. PULS QS5.241 Test Results

Duration			Percent of Nominal					SEMI F47	Results
Seconds	60Hz Cycles	50Hz Cycles	120Vac 60Hz	120Vac 50Hz	208Vac 60Hz	208Vac 50Hz			
1	60	50	47.5%	47%	25%	25%	80%	Passed	
0.5	30	25	47.5%	47.5%	25%	25%	80%	Passed	
0.5	30	25	47.5%	47.5%	25%	25%	70%	Passed	
0.25	15	12.5	47.5%	40%	25%	22%	70%	Passed	
0.2	12	10	40%	40%	23%	22%	70%	Passed	
0.2	12	10	40%	40%	23%	22%	50%	Passed	
0.17	10	8.5	40%	38%	22%	20%	50%	Passed	
0.08	5	4	35%	35%	18%	18%	50%	Passed	
0.07	4	3.5	35%	33%	18%	15%	50%	Passed	
0.05	3	2.5	30%	25%	15%	15%	50%	Passed	
0.03	2	1.5	0%	0%	0%	0%	Unspecified	N/A	
0.02	1	1	0%	0%	0%	0%	Unspecified	N/A	

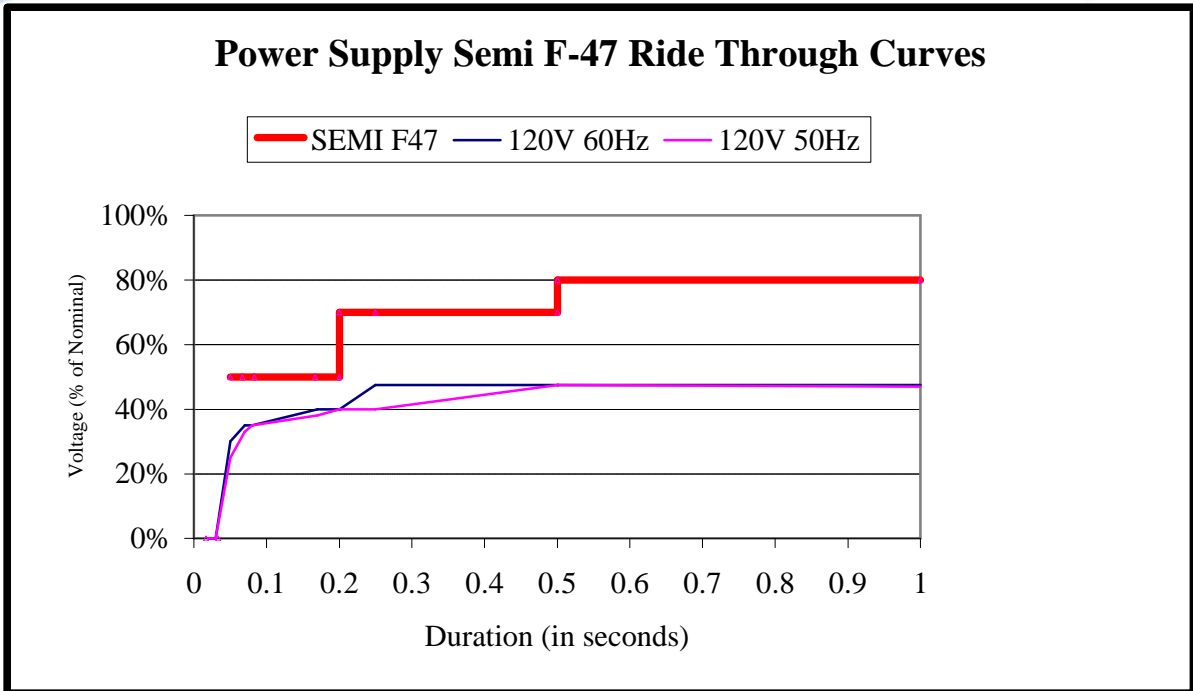

Figure A-1. PULS QS5.241 SEMI F47 Ride-Through Curve at 120Vac

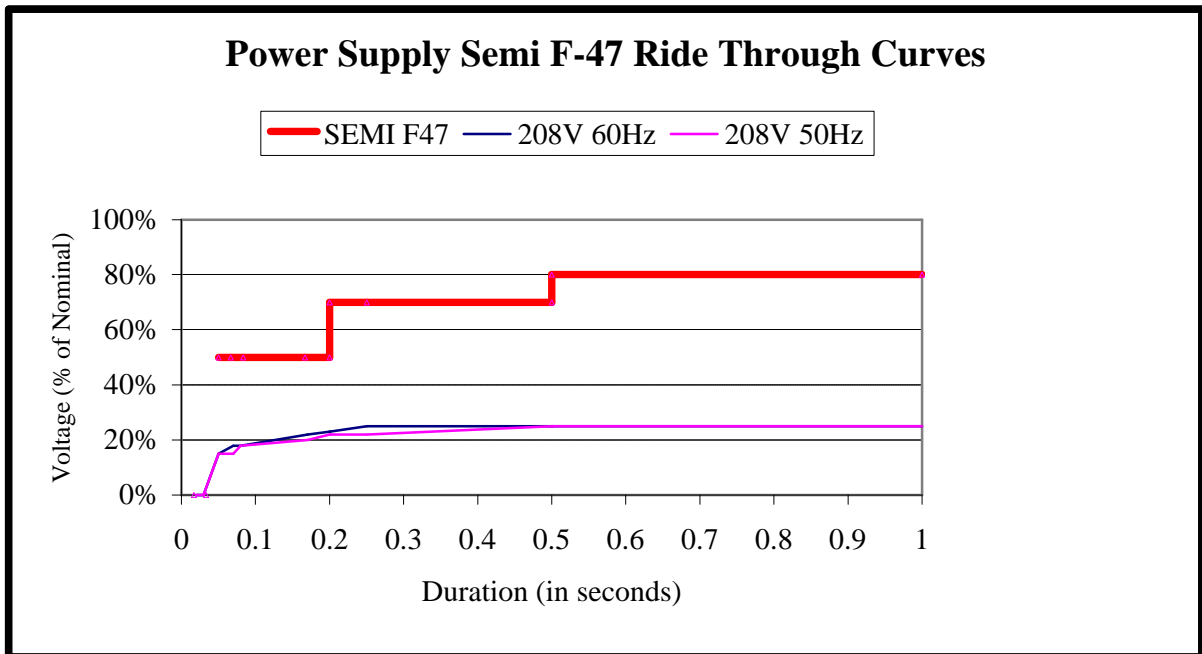

Figure A-2. PULS QS5.241 SEMI F47 Ride-Through Curve at 208Vac



Electrical Environment

Steady state measurements were taken prior to testing. Table A-3 lists measurements taken to characterize the electrical environment of the power supply during SEMI F47 compliance testing, at 50/60 Hz.

Table A-3. Steady State Measurements for PULS QS5.241

Measurement Parameters	Test Process State	Test Process State	Test Process State	Test Process State
	120V/60Hz	120V/50 Hz	208V/60Hz	208V/50Hz
Rated Voltage P-P	120-240	120-240	120-240	120-240
Voltage (Va-b)	120	120	208	208
Current (Ia)	1.11	1.09	.67	.69
Power (Wa-n)	130	130	130	130
Volt Amps (VA)	132	132	140	140
Vthd (Phase A) %	.6	.6	.4	.4
Ithd (Phase A) %	7.8	7.9	18.6	20.0
I1	99.7	99.7	98.2	98.2
I3	6.0	6.2	16	18
I5	3.6	3.4	6.9	7.0
Power Factor	.99	.99	.90	.90
Crest Factors	1.48	1.48	1.62	1.64
Hertz	60	50	60	50

Attachment B - Test Configuration

Test Configuration

The SEMI F42 compliant voltage sag generator was placed in series with the main power feed, in accordance with SEMI F42 and shown in Figure B-1. The main power feed for this test was an amplifier that was adjustable for voltage and frequency. This allowed a precise setting of 120/208Vac and 50/60 Hz. A photo of the setup is shown in Figure B-2.

Figure B-1. Test Configuration and Setup

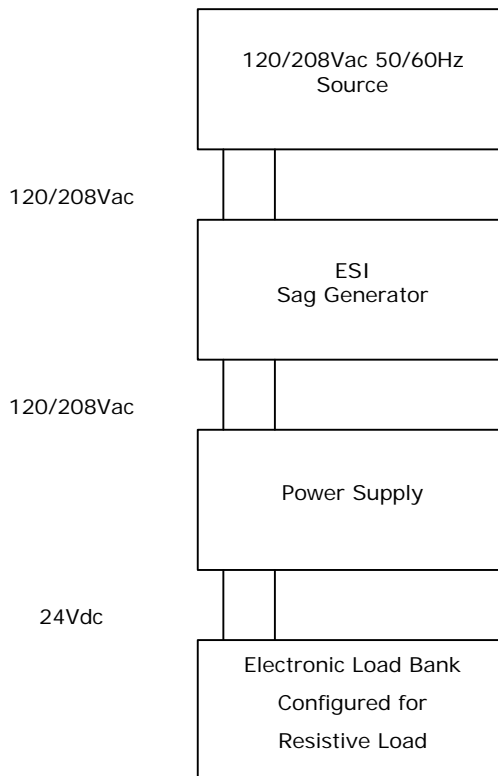
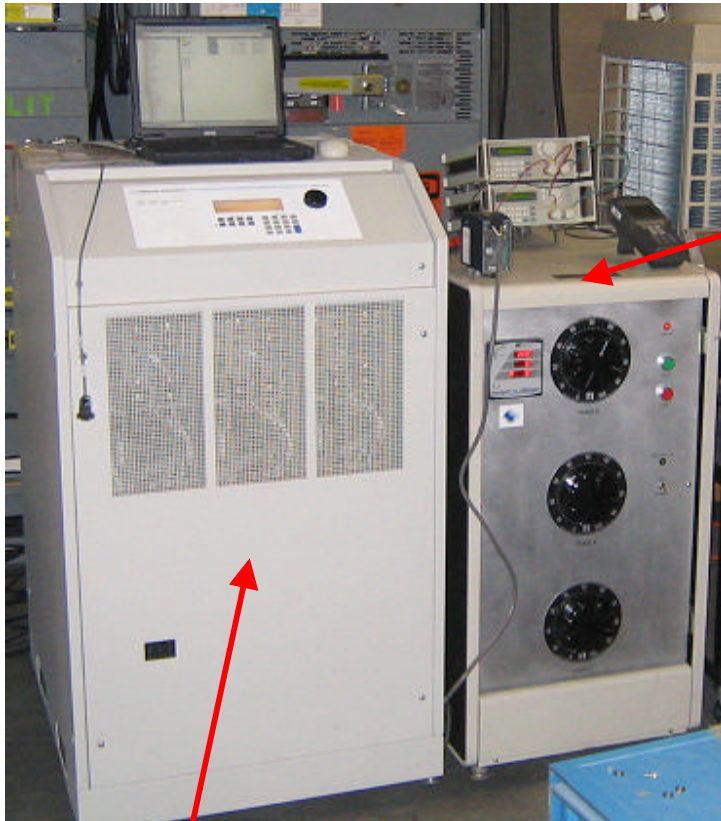

Figure B-2. Photo of Test Setup



Voltage Sag Generator,
Electronic Load Banks and
Power Supply under test

45kVA 3-Phase
Programmable Voltage
Source

Attachment C - SEMI F47 Abstract

The SEMI F47 “Specification for Semiconductor Processing Equipment Voltage Sag Immunity” document defines the threshold that a semiconductor tool must operate without interruption (per SEMI F42) and it also provides a target for the facility and utility systems. The Recognizing semiconductor factories require high levels of power quality due to the sensitivity of equipment and process controls and that Semiconductor processing equipment is especially vulnerable to voltage sags, this document defines the voltage sag ride-through capability required for semiconductor processing, metrology, and automated test equipment.

The requirements in this international standard were developed to satisfy semiconductor industry needs. While more stringent than existing generic standards, this industry-specific specification is not in conflict with known generic equipment regulations from other regions or generic equipment standards from other organizations. It is the intent of this standard to provide specifications for semiconductor processing equipment that will lead to improved selection criteria for sub-components and improvements in equipment systems design. While it is recognized that in certain extreme cases or for specific functions battery storage devices may be appropriate, it is not the intent of this standard to increase the size or use of battery storage devices provided with equipment. Focus on improvements in equipment component and system design should lead to a reduction or elimination in the use of battery storage devices to achieve equipment reliability during voltage sag events.

The SEMI F47 document specifies the minimum voltage sag ride-through capability design requirements for equipment used in the semiconductor industry. The expected equipment performance capability is shown graphically on a chart representing voltage sag duration and percent deviation of equipment nominal voltage. The primary focus for this specification is semiconductor processing equipment including but not limited to the following tool types:

- Etch equipment (Dry & Wet)
- Film deposition equipment (CVD & PVD)
- Thermal equipment
- Surface prep and clean
- Photolithography equipment (Stepper & Tracks)
- Chemical Mechanical Polishing equipment
- Ion Implant equipment
- Metrology equipment
- Automated test equipment

The actual SEMI F47 ride-through curve is shown below.

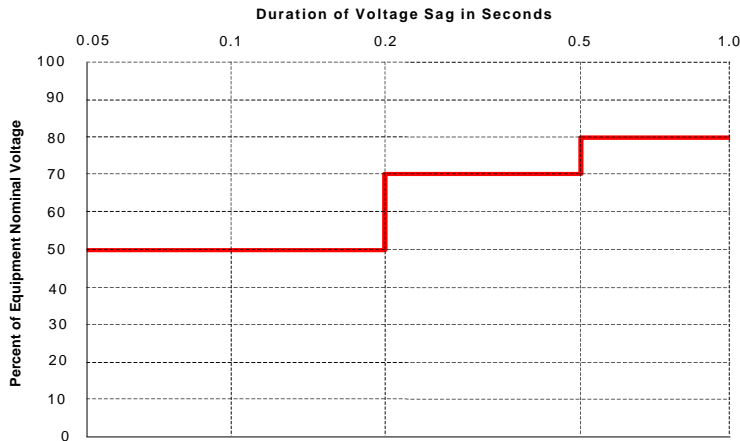

Figure C-1. The SEMI F47 Voltage Sag Ride-Through Curve

The specification states that Semiconductor processing, metrology, and automated test equipment must be designed and built to conform to the voltage sag ride-through capability per the defined curve. Equipment must continue to operate without interrupt (per SEMI E10) during conditions identified in the area above the defined line. In the context of SEMI F47, interrupt means any assist or failure. An assist is defined as an unplanned interruption that occurs during an equipment cycle where all three of the following conditions apply:

- The interrupted equipment cycle is resumed through external intervention (e.g., by an operator or user, either human or host computer).
- There is no replacement of a part, other than specified consumables.
- There is no further variation from specification of equipment operation.

Furthermore, a failure is any unplanned interruption or variance from the specifications of equipment operation other than assists. Although no variation in the tool's process is the goal, this standard addresses these issues as related to the equipment operation only.



PQ Star Certification for the Semiconductor Industry

Having conducted power quality tests on hundreds of devices and electrical equipment since 1992, EPRI Solutions, Incorporated Power Delivery Unit (Formerly EPRI PEAC Corporation) is known worldwide for power quality testing expertise. Since April 1997, ESI has conducted voltage sag testing on semiconductor processing tools. In order to serve the semiconductor industry, ESI has established a certification program to test manufacturer equipment per established power quality standards. PQ Star certification for the SEMI F47 standard (Specification for semiconductor Processing Equipment Voltage Sag Immunity) is now available for semiconductor equipment suppliers. ESI utilizes the SEMI F42 test standard (Test Method for Semiconductor Processing Equipment Voltage Sag Immunity). With the PQ Star certification, ESI offers a third party verification that the equipment tested meets this important new power quality standard.

For more information about the PQ Star test program for the semiconductor industry or inquire about testing see www.F47testing.com or call us at 865-218-8000.